

**0.5A 180KHz 70V Buck DC to DC Converter****XL7005****Features**

- Wide 5V to 70V Operation Voltage
- Output Adjustable from 1.25V to 18V
- Maximum Duty Cycle 100%
- Minimum Drop Out 1V
- Fixed 180KHz Switching Frequency
- 0.5A Constant Output Current Capability
- Internal Optimize HV Power Transistor
- High efficiency up to 85%
- Excellent line and load regulation
- TTL shutdown capability
- Built in thermal shutdown function
- Built in output short Protection Function
- Built in current limit function
- Available in SOIC8 package

**Applications**

- Ebike Controller Power Supply
- Telecom / Networking Equipment

**General Description**

The XL7005 is a 180KHz fixed frequency PWM buck (step-down) DC/DC converter, capable of driving a 0.5A load with high efficiency, low ripple and excellent line and load regulation. Requiring a minimum number of external components, the regulator is simple to use and include internal frequency compensation and a fixed-frequency oscillator.

The PWM control circuit is able to adjust the duty ratio linearly from 0 to 100%. An enable function, an over current protection function is built inside. When output short protection function happens, the operation frequency will be reduced from 180KHz to 40KHz. An internal compensation block is built in to minimize external component count.



SOIC-8

Figure1. Package Type of XL7005

**0.5A 180KHz 70V Buck DC to DC Converter**

**XL7005**

**Pin Configurations**

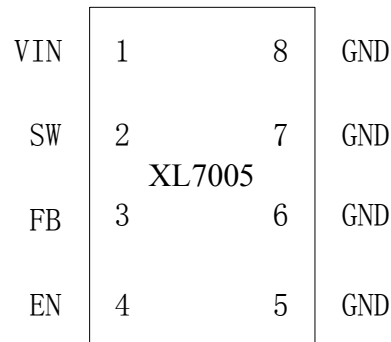

Figure2. Pin Configuration of XL7005 (Top View)

Table 1 Pin Description

Pin Number	Pin Name	Description
1	VIN	Supply Voltage Input Pin. XL7005 operates from a 5V to 70V DC voltage. Bypass Vin to GND with a suitably large capacitor to eliminate noise on the input.
2	SW	Power Switch Output Pin (SW). Output is the switch node that supplies power to the output.
5~8	GND	Ground Pin. Care must be taken in layout. This pin should be placed outside of the Schottky Diode to output capacitor ground path to prevent switching current spikes from inducing voltage noise into XL7005.
3	FB	Feedback Pin (FB). Through an external resistor divider network, Feedback senses the output voltage and regulates it. The feedback threshold voltage is 1.25V.
4	EN	Enable Pin. Drive EN pin low to turn on the device, drive it high to turn it off. Floating is default low.

**0.5A 180KHz 70V Buck DC to DC Converter**

**XL7005**

**Function Block**

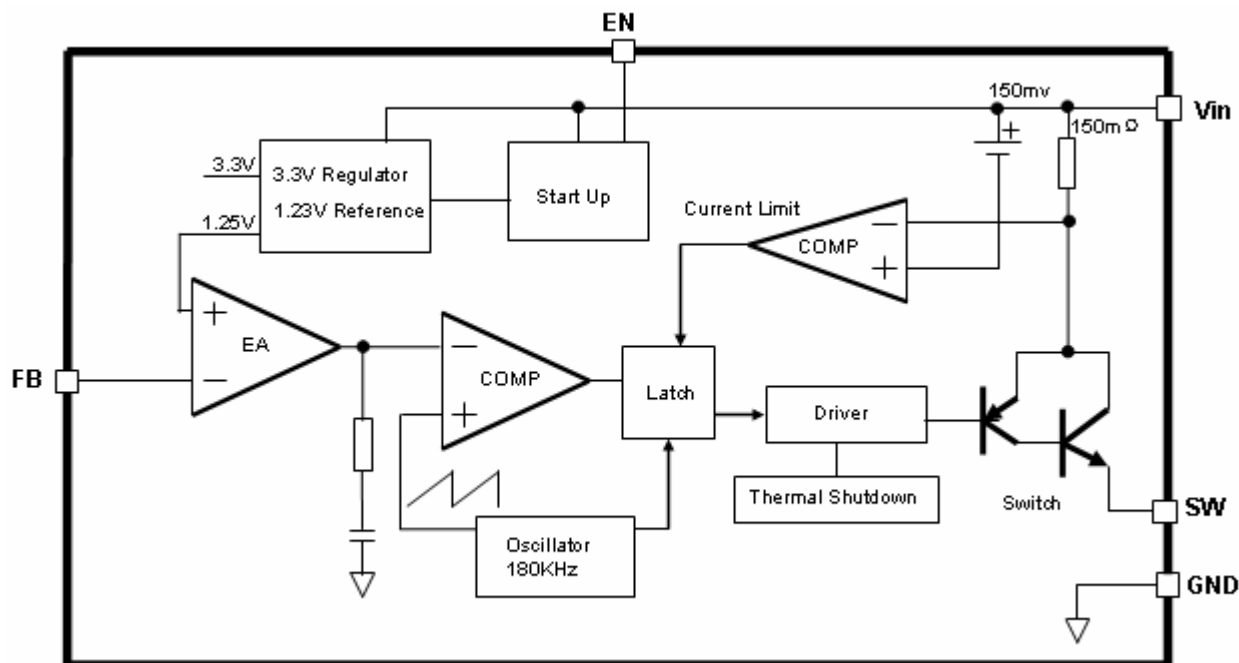

Figure3. Function Block Diagram of XL7005

**Typical Application Circuit**

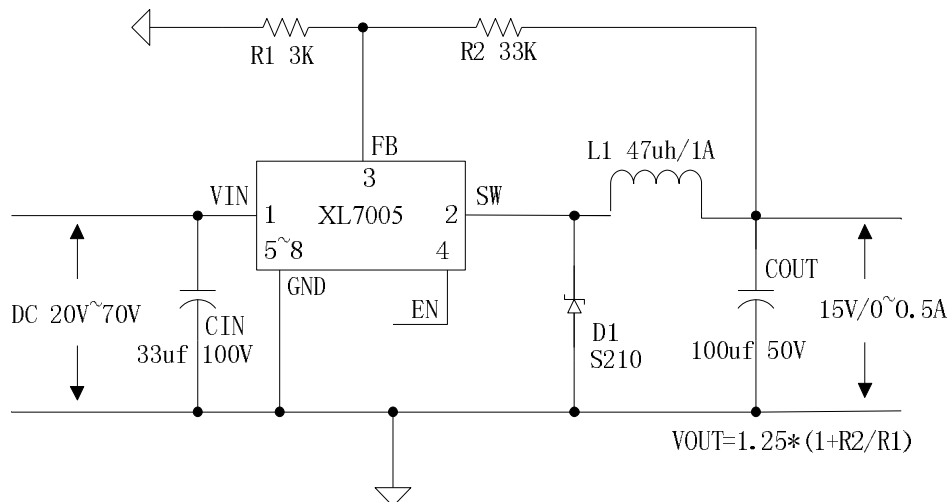

Figure4. XL7005 Typical Application Circuit

**0.5A 180KHz 70V Buck DC to DC Converter**

**XL7005**

**Ordering Information**

Order Information	Marking ID	Package Type	Packing Type Supplied As
XL7005E1	XL7005E1	SOIC-8	2500 Units on Tape & Reel

XLSEMI Pb-free products, as designated with “E1” suffix in the par number, are RoHS compliant.

**Absolute Maximum Ratings (Note1)**

Parameter	Symbol	Value	Unit
Input Voltage	V <sub>in</sub>	-0.3 to 75	V
Feedback Pin Voltage	V <sub>FB</sub>	-0.3 to V <sub>in</sub>	V
EN Pin Voltage	V <sub>EN</sub>	-0.3 to V <sub>in</sub>	V
Output Switch Pin Voltage	V <sub>SW</sub>	-0.3 to V <sub>in</sub>	V
Power Dissipation	P <sub>D</sub>	Internally limited	mW
Thermal Resistance (SOIC8) (Junction to Ambient, No Heatsink, Free Air)	R <sub>JA</sub>	100	°C/W
Operating Junction Temperature	T <sub>J</sub>	-40 to 125	°C
Storage Temperature	T <sub>STG</sub>	-65 to 150	°C
Lead Temperature (Soldering, 10 sec)	T <sub>LEAD</sub>	260	°C
ESD (HBM)		>3000	V

**Note1:** Stresses greater than those listed under Maximum Ratings may cause permanent damage to the device. This is a stress rating only and functional operation of the device at these or any other conditions above those indicated in the operation is not implied. Exposure to absolute maximum rating conditions for extended periods may affect reliability.

**0.5A 180KHz 70V Buck DC to DC Converter**

**XL7005**

**XL7005 Electrical Characteristics**

T<sub>a</sub> = 25 °C ;unless otherwise specified.

Symbol	Parameter	Test Condition	Min.	Typ.	Max.	Unit
<i>System parameters test circuit figure4</i>						
VFB	FB Voltage	V <sub>in</sub> = 20V to 70V I <sub>load</sub> =0.05A to 0.5A	1.225	1.25	1.275	V
Efficiency	η	V <sub>in</sub> =36V ,V <sub>out</sub> =15V I <sub>out</sub> =0.5A	-	85	-	%
Efficiency	η	V <sub>in</sub> =48V ,V <sub>out</sub> =15V I <sub>out</sub> =0.5A	-	78	-	%
Efficiency	η	V <sub>in</sub> =60V ,V <sub>out</sub> =15V I <sub>out</sub> =0.5A	-	76	-	%

**Electrical Characteristics (DC Parameters)**

V<sub>in</sub> = 48V, GND=0V, V<sub>in</sub> & GND parallel connect a 47uf/80V capacitor; I<sub>out</sub>=0.25mA, T<sub>a</sub> = 25 °C ; the others floating unless otherwise specified.

Parameters	Symbol	Test Condition	Min.	Typ.	Max.	Unit
Input operation voltage	V <sub>in</sub>		5		70	V
Shutdown Supply Current	I <sub>STBY</sub>	V <sub>EN</sub> =2V		85	200	uA
Quiescent Supply Current	I <sub>q</sub>	V <sub>ON/OFF</sub> =0V, V <sub>FB</sub> =V <sub>in</sub>		2.5	10	mA
Oscillator Frequency	F <sub>osc</sub>		144	180	216	KHz
Switch Current Limit	I <sub>L</sub>	V <sub>FB</sub> =0		0.7		A
EN Pin Threshold	V <sub>EN</sub>	High (Regulator OFF) Low (Regulator ON)		1.6 0.8		V
EN Pin Input Leakage Current	I <sub>H</sub>	V <sub>EN</sub> =2.5V (OFF)		6	20	uA
	I <sub>L</sub>	V <sub>EN</sub> =0.5V (ON)		1	10	uA
Output Saturation Voltage	V <sub>CE</sub>	V <sub>FB</sub> =0V I <sub>out</sub> =0.5A		0.88	1	V
Max. Duty Cycle	D <sub>MAX</sub>	V <sub>FB</sub> =0V		100		%

**0.5A 180KHz 70V Buck DC to DC Converter**

**XL7005**

**Typical System Application**

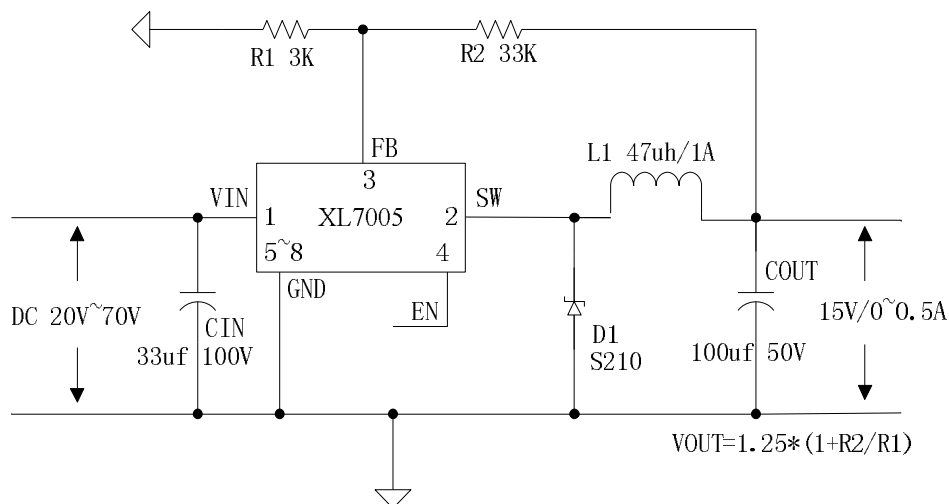

Figure5. XL7005 System Application (VIN=20V~70V, VOUT=15V)

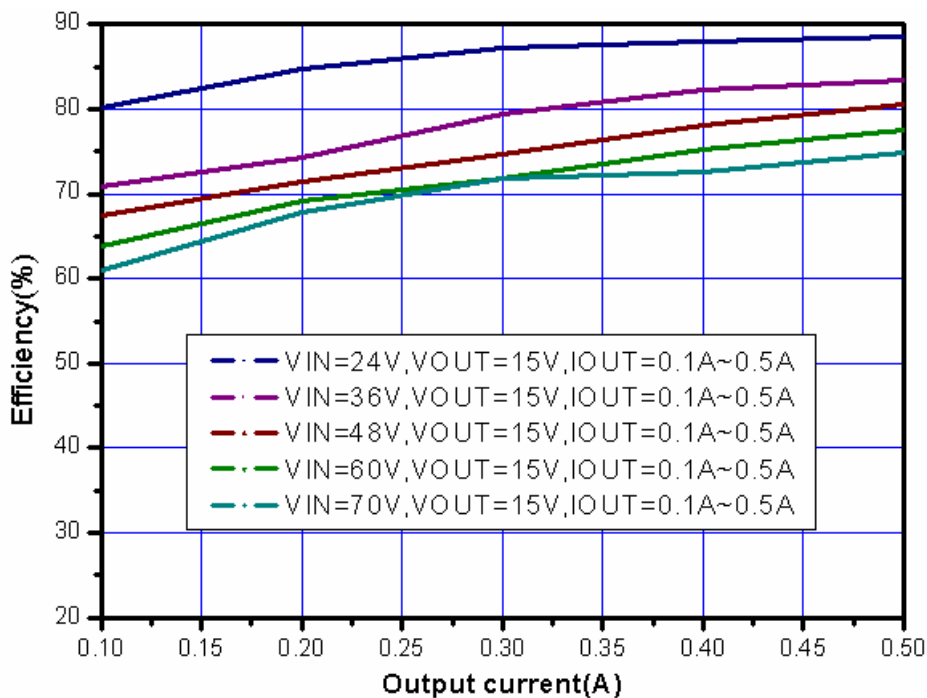

Figure6. XL7005 System Application (Efficiency VS Output Current)

